

mechanisch

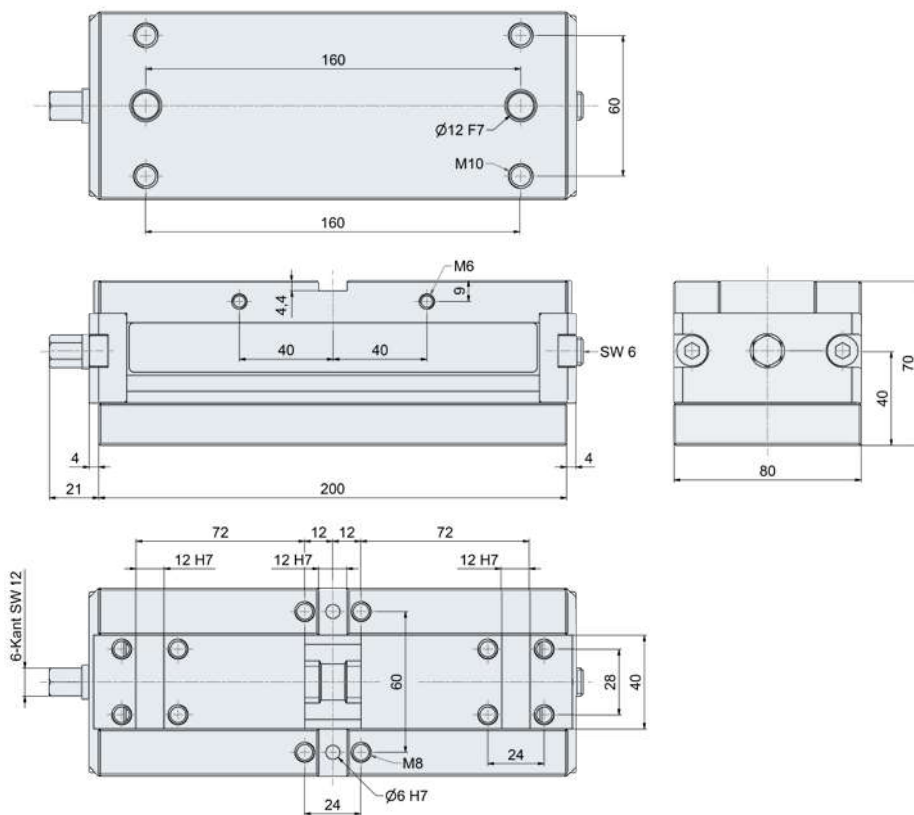

Trigo DUO 80-200 mechanisch

Spannkraft mechanisch	12 kN / 50 Nm
Spannschlittengesamthub A	2 x 12 mm
Spannwiederholgenauigkeit	± 0,01 mm
Gewicht	7,1 kg
Bestell-Nr.	DUO 80-200

Spannbackendetails siehe Rubrik 6

Zubehör siehe Rubrik 7

Fenstufenwendebacken +
Feinstufenmittenbacke

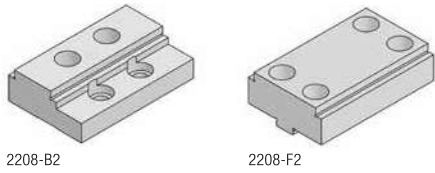

2208-B2

2208-F2

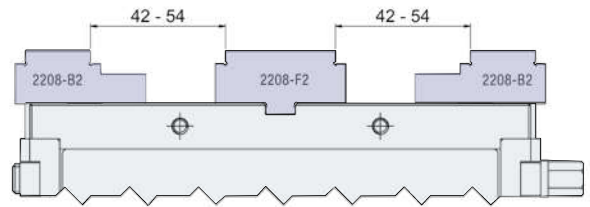

Bewegliche
Stufenwendebacke +
Stufenmittenbacke

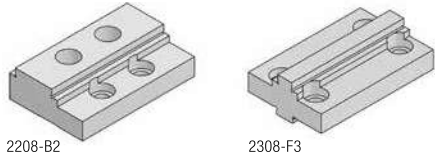

2208-B2

2308-F3

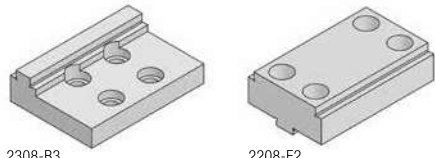
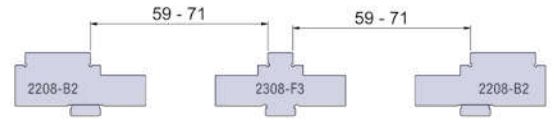

2308-B3

2208-F2

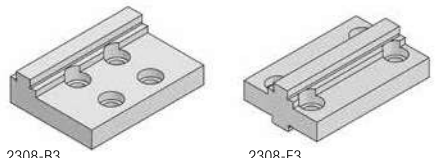
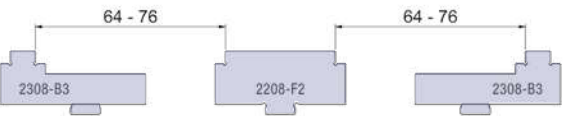

2308-B3

2308-F3

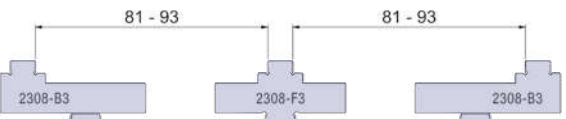

Spezial-Grip-Backe +
Spezial-Grip-Mittenbacke

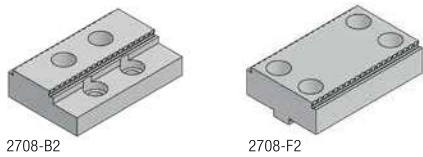

2708-B2

2708-F2

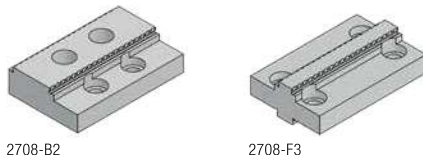
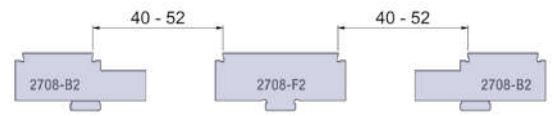

2708-B2

2708-F3

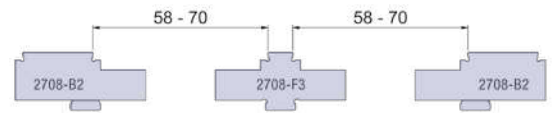

Harte Backen
ohne Stufen

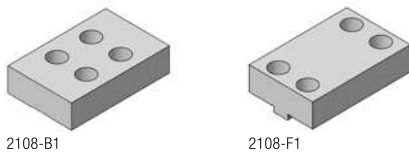

2108-B1

2108-F1

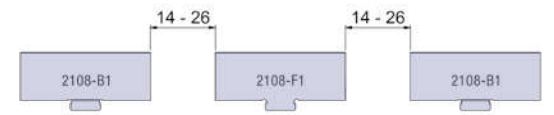

Bewegliche
Wendebacke, weich
+
Mittenbacke, weich

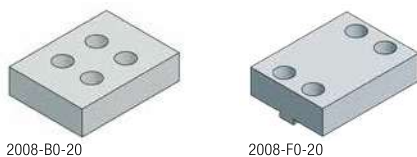

2008-B0-20

2008-F0-20

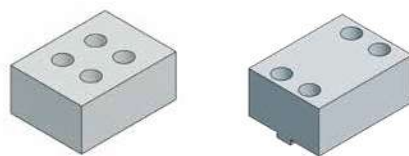

2008-B0-35

2008-F0-35

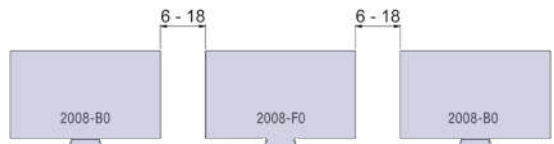

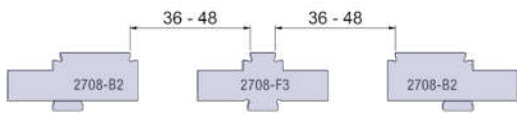
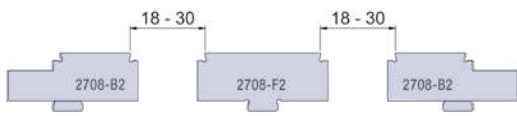
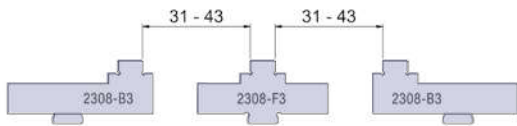
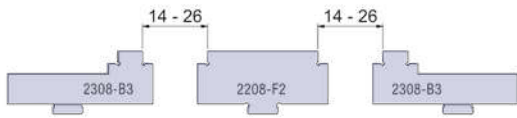
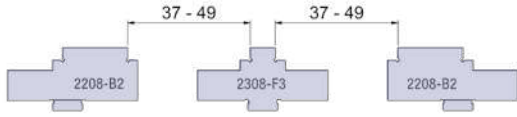
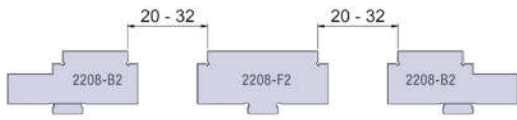

Keine komplette Spannbereichsüberdeckung

Spannbackendetails siehe Rubrik 6

Zubehör siehe Rubrik 7